



## 9 KG MANUAL COIN OPERATED ELECTRIC DRYER

### Features and Benefits

- Super strength, high security, double wrapped steel front money vault discourages and prevents vandalism.
- 100% front service dryer reduces maintenance time and costs ensuring maximum availability.
- Rear controls matching the SWNSX2 top load coin operated washer for perfect pairing of both capacity and style.
- 4,000 w heater element for fast, efficient drying.

### SPECIFICATIONS

DIMENSIONS	
CAPACITY	9 kg
WIDTH	683 mm
DEPTH	711 mm
HEIGHT	1,114 mm
DRUM VOLUME	198 litres
NET WEIGHT	61 kg
OPERATION	
CYCLES	4 cycles, 3 fabric temperatures
CYCLE INDICATOR	Yes
CYCLE TIME	Variable to suit desired vend price
CONTROLS	Manual
ACTIVATION	Manual coin slide or token
HEAT INPUT	4,000 w
MOTOR	1/3 hp
ELECTRICAL	20 amp single phase
CONSTRUCTION	
DRUM	Galvanised steel
OUTER CABINET	Steel



# SDESXR Commercial Dryer



## TECHNICAL SPECIFICATIONS

### UTILITIES

20 AMP SINGLE PHASE 240 V 50 HZ
20 AMP CIRCUIT-BREAKER REQUIRED
1.8 M POWER CORD
FLUE DIAMETER 102 MM (4 IN)
AIR FLOW 85 LITERS / SEC
MAX POWER DRAW 4,000 W / HR
OPTIONAL RIGHT OR LEFT SIDE VENTING

### SHIPPING DIMENSIONS

WEIGHT	73 kg
HEIGHT	1,143 mm
WIDTH	775 mm
DEPTH	762 mm
	0.67 m <sup>3</sup>

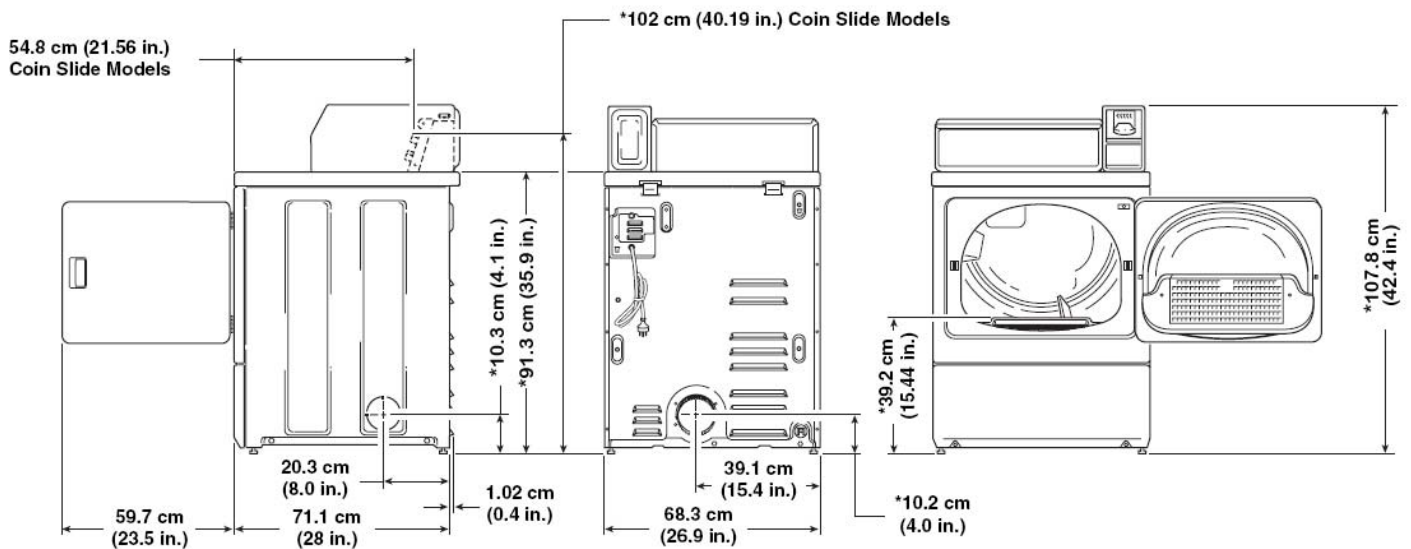

### WESTERN AUSTRALIA

7/15 Walters Drive  
Osbourne Park WA 6017  
T: 08 9445 7744  
enquiry@speedqueenwa.com.au

### NEW SOUTH WALES & ACT

245 Rawson Street  
Auburn NSW 2144  
T: 02 9748 2155  
enquiry@speedqueenlaundry.com.au

### SOUTH AUSTRALIA & NT

385-387 Main North Road  
Enfield SA 5085  
T: 08 7095 0336  
sa@speedqueenlaundry.com.au

### QUEENSLAND

2/18 Gravel Pit Road  
Darra QLD 4076  
T: 07 3376 3869 \*Home retail  
qld@speedqueenlaundry.com.au

\*For the most accurate information, the installation guide should be used for all design and construction purposes. Due to continuous product improvements, design and specifications are subject to change without notice.