

LTGE5A Commercial Washer/Dryer



10KG FRONT LOAD WASHER AND STACKED 9 KG GAS DRYER

Features and Benefits

- Low water consumption of only 44.3 litres per wash on a standard cycle with NO options with full wash completed in 30 minutes.
- Pre-Wash and extra rinse option for heavily soiled loads.
- Energy saving 'High Speed Extract' spin cycle of 1,200 rpm producing 'G' forces in excess of 440 for greater water removal, resulting in reduced drying times and associated energy savings.
- 100% front service dryer.

SPECIFICATIONS

DIMENSIONS	
CAPACITY	10 kg washer, 9 kg dryer
WIDTH	683 mm
DEPTH	704 mm
HEIGHT	1,986 mm
NET WEIGHT	177 kg
OPERATION	
WASHER CYCLES	6 Cycles, 3 Soil Levels
DRYER CYLES	6 Cycles, 3 Fabric Temperatures
LIGHTS CONTROLS	Yes & Timer Display
ACTIVATION	Electronic E MECH
WATER TEMPERATURE	Hot, warm or cold
MOTOR WASHER SPIN	1 hp, variable speed
SPEED WASHER	500 - 1,200 rpm, variable speed
WATER USE WASHER	44.3 litres / wash standard cycle
HEAT INPUT DRYER	21.9 mj natural gas or LPG
CONSTRUCTION	
DRUM WASHER	Stainless steel
OUTER BOWL WASHER	Stainless steel
OUTER CABINET	Steel
DRUM DRYER	Galvanised



LTGE5A Commercial Washer/Dryer



TECHNICAL SPECIFICATIONS

UTILITIES WASHER

10 AMP SINGLE PHASE 240 V 50 HZ
10 AMP CIRCUIT-BREAKER REQUIRED
1.8 M POWER CORD
HOT AND COLD WATER CONNECTIONS REQUIRED
1.2 M HOT AND COLD WATER HOSES SUPPLIED
WATER SUPPLY HOSE TAP ENDS 3/4 BSP THREADS
MAX HOT WATER CONSUMPTION 31 LITRE / CYCLE (INC PRE-WASH)
MAX WATER CONSUMPTION 74.2 LITRE / CYCLE
MAX POWER DRAW 750 W / HR
DRAIN: 610 - 914 MM UPSTAND, 50 MM DIAMETER
WATER SUPPLY PRESSURE BETWEEN 140 KPA/825 KPA

UTILITIES DRYER

10 AMP SINGLE PHASE	240 V 50 Hz
10 AMP	Circuit-breaker required
1.8 M	Power Cord
FLUE DIAMETER	102 mm (4 in)
AIR FLOW	85 litres / second
MAX POWER DRAW	4,000 w / hour
OPTIONAL	Right or left side venting

SHIPPING DIMENSIONS

WEIGHT	193 kg
HEIGHT	2,032 mm
WIDTH	737 mm
DEPTH	832 mm
	1.25 m ³

A) *1678 mm	B) *1447 mm	C) 597 mm	D) 213 mm	E) 610 mm
F) 203 mm	G) 391 mm	H) 59 mm	I) *938 mm	J) *368 mm
K) *1140 mm	L) *813 mm	M) 683 mm	N) *1184 mm	O) *1986 mm
P) 52 mm	Q) 704 mm	R) 38 mm	S) *333 mm	

* With Leveling Legs Turned into Base.

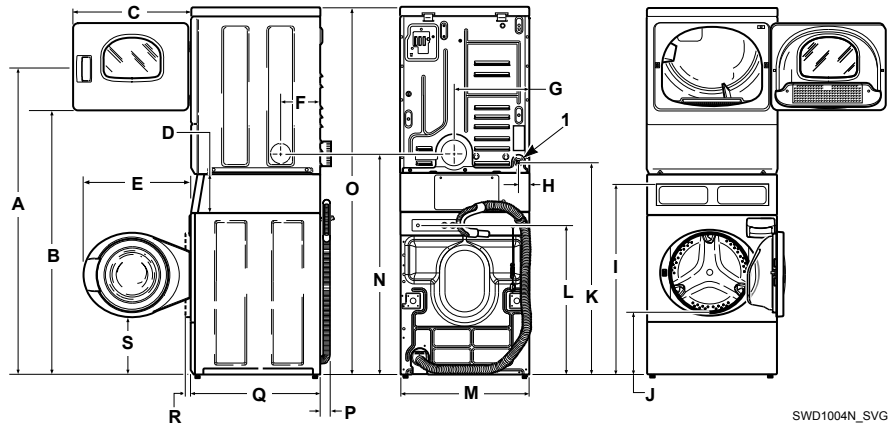

SWD1004N_SVG

WESTERN AUSTRALIA

7/15 Walters Drive
Osbourne Park WA 6017
T: 08 9445 7744
enquiry@speedqueenwa.com.au

NEW SOUTH WALES & ACT

245 Rawson Street
Auburn NSW 2144
T: 02 9748 2155
enquiry@speedqueenlaundry.com.au

SOUTH AUSTRALIA & NT

385-387 Main North Road
Enfield SA 5085
T: 08 7095 0336
sa@speedqueenlaundry.com.au

QUEENSLAND

2/18 Gravel Pit Road
Darra QLD 4076
T: 07 3376 3869 *Home retail
qld@speedqueenlaundry.com.au

*For the most accurate information, the installation guide should be used for all design and construction purposes. Due to continuous product improvements, design and specifications are subject to change without notice.