



## 9 KG TOUCH CONTROL, ELECTRONIC COIN DROP GAS DRYER

### Features and Benefits

- Super strength, high security, double wrapped steel front money vault discourages and prevents vandalism.
- 100% front service dryer reduces maintenance time and costs ensuring maximum availability.
- Front controls matching the SFNXXA front load coin operated washer for perfect paring of both capacity and style.
- 27Mj gas fueled burner for reduced energy costs and faster, efficient drying.
- Electronic coin mechanism will accept 20c, \$1, \$2 or a token while rejecting foreign currency, with the vend price adjustable in seconds with no hardware changes required.

### SPECIFICATIONS

DIMENSIONS	
CAPACITY	9 kg
WIDTH	683 mm
DEPTH	711 mm
HEIGHT	1,092 mm
DRUM VOLUME	198 litres
NET WEIGHT	68 kg
OPERATION	
CYCLES	5 cycles, 4 fabric temperatures
CYCLE INDICATOR	Yes, digital display
CYCLE TIME	Variable to suit desired vend price
CONTROLS	Electronic
ACTIVATION	Card, Token, Electronic coin drop
HEAT INPUT	27Mj Natural Gas or LPG
MOTOR	1/3 hp, 0.25kw
POWER SUPPLY	10amp, single phase
CONSTRUCTION	
DRUM	Galvanised
OUTER CABINET	Steel



# SDGNXA Commercial Dryer



## TECHNICAL SPECIFICATIONS

### UTILITIES

SINGLE PHASE 240 V 50 HZ 10 AMP
10 AMP CIRCUIT-BREAKER REQUIRED
1.8 M POWER CORD
27MJ NATURAL GAS OR LPG
FLUE DIAMETER 102 MM (4 INCH)
AIR FLOW 85 LITRES / SECOND
OPTIONAL RIGHT HAND SIDE VENTING

### SHIPPING DIMENSIONS

WEIGHT	66 kg
HEIGHT	1,143 mm
WIDTH	775 mm
DEPTH	762 mm
	0.67 m <sup>3</sup>

A \*1126 mm [44.34 in.]  
 D \*102 mm [4 in.]  
 G 391 mm [15.4 in.]  
 J 10 mm [0.4 in.]  
 M 597 mm [23.5 in.]

B \*938 mm [36.94 in.]  
 E \*70 mm [2.8 in.]  
 H 683 mm [26.875 in.]  
 K 203 mm [8 in.]

C \*392 mm [15.44 in.]  
 F 60 mm [2.3 in.]  
 I \*114 mm [4.5 in.]  
 L 711 mm [28 in.]

\* With leveling legs turned into base.

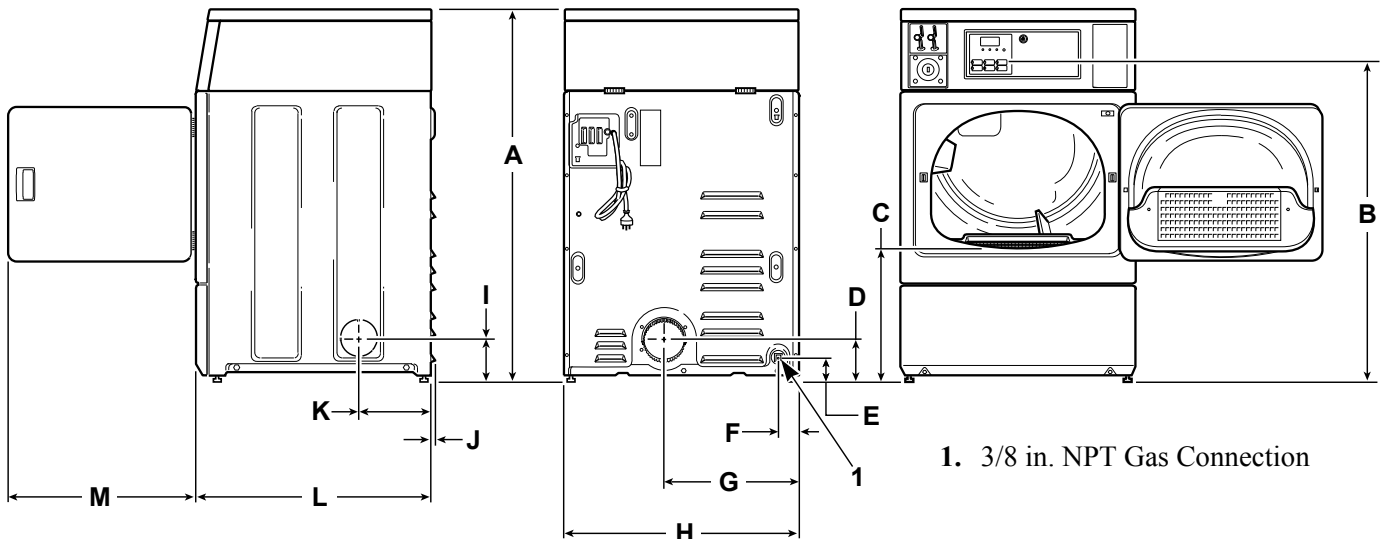

### WESTERN AUSTRALIA

7/15 Walters Drive  
 Osbourne Park WA 6017  
 T: 08 9445 7744  
 enquiry@speedqueenwa.com.au

### NEW SOUTH WALES & ACT

245 Rawson Street  
 Auburn NSW 2144  
 T: 02 9748 2155  
 enquiry@speedqueenlaundry.com.au

### SOUTH AUSTRALIA & NT

385-387 Main North Road  
 Enfield SA 5085  
 T: 08 7095 0336  
 sa@speedqueenlaundry.com.au

### QUEENSLAND

2/18 Gravel Pit Road  
 Darra QLD 4076  
 T: 07 3376 3869 \*Home retail  
 qld@speedqueenlaundry.com.au

\*For the most accurate information, the installation guide should be used for all design and construction purposes. Due to continuous product improvements, design and specifications are subject to change without notice.